

TECH/OPS



MILLIPAK SBPM CONTROLLER MANUAL
FOR SYSTEM VERSION UK0123

Document History

Document History

Author		Reviewer		Version	Reason for Modification
Initials	Date	Initials	Date		
PG	08 Dec 04	-	-	UK0123	Original.

CONTENTS

Introduction..... 5

Safety 6

Installation..... 7

 MOUNTING.....7

 MILLIPAK BPM POWER WIRING.....8

 MILLIPAK LIGHT WIRING EXAMPLE.....9

Calibrator 11

 DRIVE HOURS COUNTER.....12

 CALIBRATOR SECURITY LEVELS13

 NAVIGATION14

 ADJUSTMENTS.....15

 STATUS AND TEST INFORMATION16

Configuration 17

 SYSTEM CONFIGURATION17

 System Voltage.....18

 System I/O Configuration.....19

 Contactor chopping.....21

 Accelerator Full /Zero Setting22

 Motor Poles23

 Maximum Motor RPM.....24

 Phase Adjustment25

 PERFORMANCE26

 Control Mode.....26

 Speed Control PI Gains.....27

 Acceleration Delay.....29

 Deceleration Delay.....29

 Maximum Speed.....30

Features 31

 STANDARD CONTROLLER FEATURES.....31

 Drive Hours Meter32

 Line Contactor Drop out.....33

 Electric Outboard Drive and Low Battery Warning34

 Temporary Current Boost35

 SAFETY FEATURES.....36

 Start Up Sequence36

 Idle Fault37

 Motor Stall Protection.....38

 Fail-safe.....39

Controller Protection Features 40

 TEMPERATURE MONITORING.....40

 UNDER-VOLTAGE AND OVER-VOLTAGE PROTECTION.....42

Commissioning Checklist 46

 PERSONALITY RECORD47

Fault Finding..... 48

Contents

FAULT CLEARANCE.....	49
FAULT REPORTING FORM	50
SOFTWARE VERSION AND SERIAL NUMBER INDICATION	51
Specifications	52
POWER CONFIGURATIONS.....	52
EMC STANDARDS	52
SOCKET B PROTECTION.....	52
CONTACTOR DRIVE RATINGS	52
ANALOGUE INPUT IMPEDANCE	52
DIGITAL INPUT IMPEDANCE	52
EMC Guidelines.....	53

Introduction

The MillipaK SBPM (Sinusoidal Brushless Permanent Magnet) range of controllers provides a new range of power frames for 24V-36V, 250A in small, highly efficient packages. This is achieved using a Sevcon patented power switching scheme and radical new construction techniques, which enable large powers to be incorporated into very small packages.

The MillipaK provides a completely sealed (IP66) unit containing both power and logic circuitry, as well as all suppression components.

MillipaK supports Sevcon's existing MOS90 calibrator for adjustment of vehicle performance characteristics.

Controllers are FLASH microprocessor based enabling field re-programming for new features and have numerous user set-up options. The MillipaK uses high frequency (silent) MOSFET power switching technology, to control a 3-phase power frame bridge. Armature current is monitored. Motor feedback is necessary in the form of position sensors. Controllers have been designed to satisfy the requirements of the relevant UL and EC standards.

Safety

The MillipaK controller contains a triple fail-safe system to give a high level of safety. If the diagnostic LED is not illuminated or flashes, the safety circuit may have tripped and the motor may not drive.

The controller must be used with a line contactor as indicated in the wiring diagrams. As blow-out magnets are fitted to contactors (except 24V) ensure that no magnetic particles can accumulate in the contact gaps and cause malfunction. Ensure that contactors are wired with the correct polarity to their power terminals as indicated by the + sign on the top moulding.

The MillipaK controller may be used with suitable onboard chargers, as supplied by Sevcon.

There are several software features which are intended to prevent inadvertent or unexpected motor movement – Accelerator power up fault and sequence checking. Some of these features cannot be disabled and the appropriate signals must be supplied to the controller before drive will be allowed.

MillipaK BPM Power Wiring

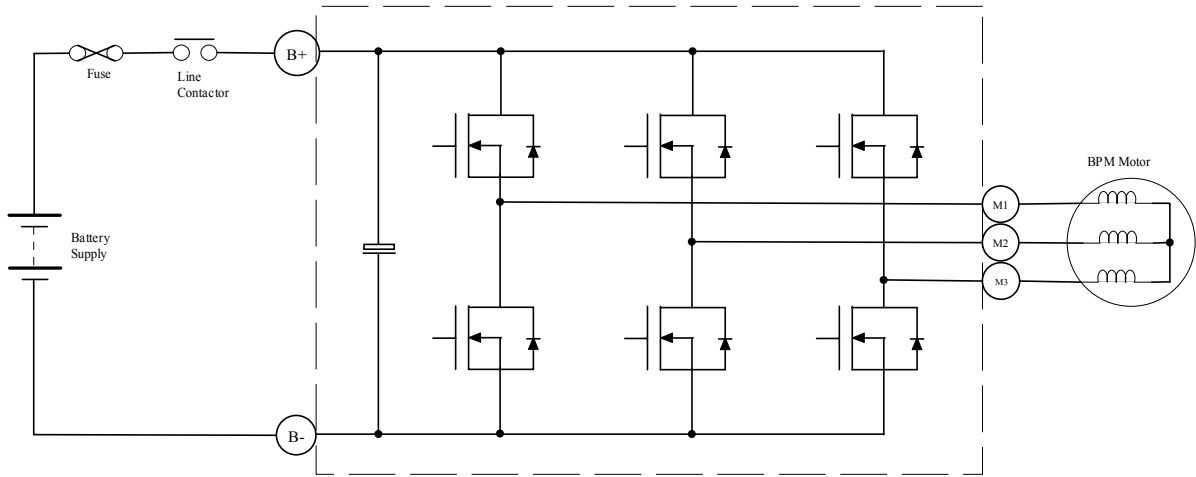
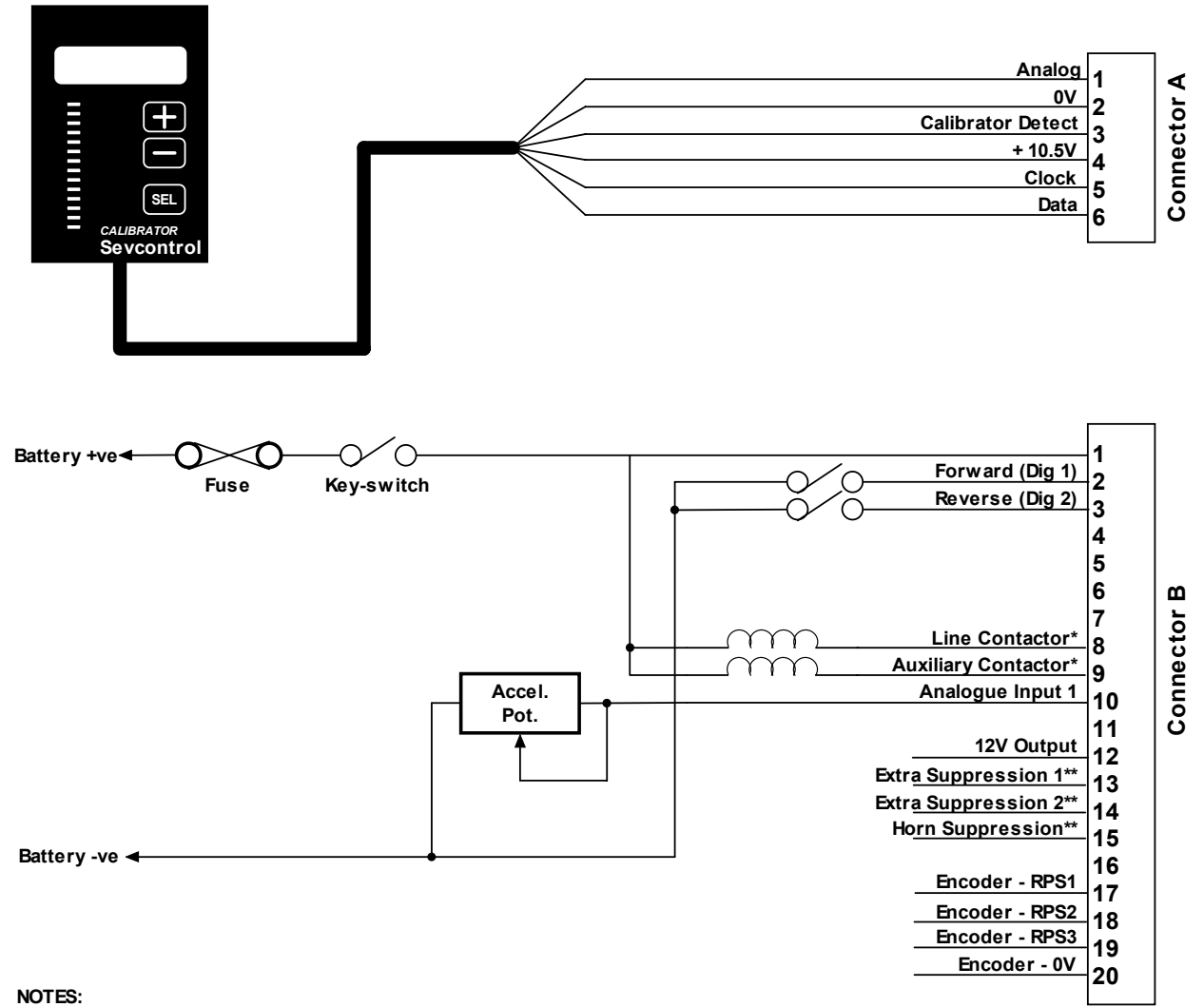

Figure 2: MillipaK BPM Power Wiring

MillipaK Light Wiring example



NOTES:

*Contactor Coil Suppression fitted internally.

**Extra Suppression and Horn Suppression inputs to be used as shown below:

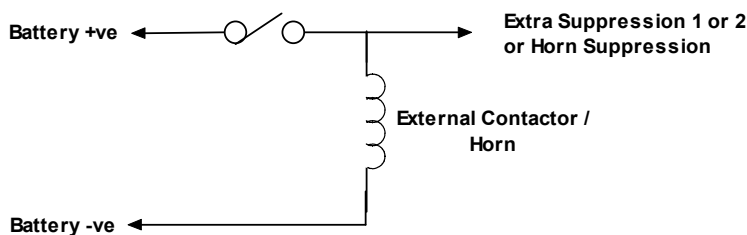

Figure 3: MillipaK Light Wiring

NOTES:

The line and auxiliary contactors are wired to B+, on the switched side of the key-switch.

Pin 12 is available for 100mA supply, typically used for (but not limited to) accelerator modules.

Pins 13,14 & 15 are general-purpose suppression connections and may be used to suppress spikes generated by contactors opening / closing. The internal configuration is shown below:

Pin 16 is used to select FLASH memory program update mode and should normally be left unconnected.

Calibrator

The Calibrator is a hand-held adjustment unit which can be used to configure and test the system. The MillipaK is designed to work with the Calibrator currently in use with SEVCON's MOS90 system. See diagram below. The menu structure is shown in the Calibrator Map located near the end of this manual.

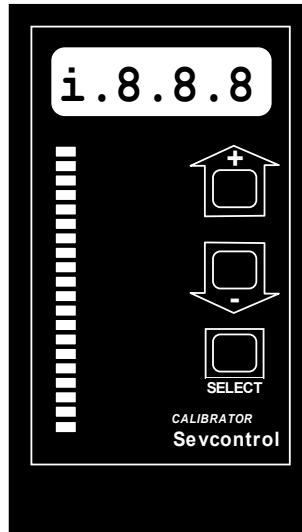

Figure 4: MillipaK Calibrator

Drive Hours Counter

When the Calibrator is first plugged into the unit after power up, the Calibrator shows the Drive Hours Counter. Refer to the Drive Hours Counter section for more information on this function.

With no buttons pressed, the number displayed shows the number of minutes (accurate to 0.5 minutes). Pressing the '-' button displays the number of hours under 1000 and pressing the '+' button displays the number of 1000 x hours.

For example, if the hours counter was 12, 345 hours, 13 minutes and 40 seconds, with no buttons pressed, the display would show 13.5. Minutes are only shown to the nearest 0.5 minutes. If the '-' button was pressed, the display would show 345 (number of hours under 1000) and if the '+' button was pressed, the display would show 12 (number of 1000 x hours).

This is the only time that the hours counter can be viewed. Once the Select button has been pressed to enter the normal calibrator menu structure, it is not possible to return to this point. To view the hours counter again, you must recycle the Keyswitch.

This is also the point at which you can enter a password to enable different levels of access to personalities. Refer to the section below on Calibrator Security Levels for more details.

Calibrator Security Levels

Which personalities and status items which can be viewed on the Calibrator is restricted using passwords. There are three levels of Calibrator access. These are shown in Table 1.

Access Level	Text	Password	Description
Service	Ser	-	Default. This level is selected when no password or an invalid password is entered. Only items shown in the Calibrator Map with a thick solid border are displayed.
Engineering	Eng	1645	All items, except those in the Setup menu, can be displayed.
All Adjust	All	Contact SEVCON	All items are be displayed, regardless of configuration.

Table 1: Calibrator Security Levels

Note, for Service and Engineering security levels only items appropriate to the current system configuration are displayed. For example, if the line contactor dropout feature is disabled then the line contactor dropout delay personality will not be displayed.

The All Adjust security level allows access to all personalities, including those not required by the current configuration. The items in the Setup menu can only be accessed at this security level.

The password can only be entered just after power up when the Traction Drive Hours Counter is displayed. The '+' and '-' buttons are used to enter the password. The first digit is entered by pressing the '+' button the appropriate number of times (i.e. once to enter 1). The second digit is entered by pressing the '-' button the appropriate number of times (i.e. 6 times to enter 6). The third digit is entered using the '+' button again and the final digit is entered using the '-' button again. Note that when the '+' or '-' buttons are pressed, the display still changes to show hours or 1000 x hours.

When the password has been completely entered press either the '+' button or the SELECT button to initiate verification. If the password has been entered correctly, the text shown in Table 1 appropriate to the required level will be displayed for 1s indicating the password was accepted. If the password was incorrect or no password was entered, the system always defaults to Service mode.

After the Security Level has been displayed, the system enters the normal menu structure shown in the Calibrator Map. To change the password level, you need to recycle the Keyswitch.

Navigation

The Calibrator uses all three buttons for navigating through the menu structure.

Use the SELECT button to move through the menu structure. When the SELECT button is pressed the next menu item is displayed. The default direction is from left to right, top to bottom.

If the '+' and '-' buttons are held down together, the ID of the currently displayed menu item is shown. For example, if the Armature Current Limit personality was selected, then the ID would be 0.01 (menu 0, item 1). This allows the operator to locate where they are in the map.

If the '+' and '-' buttons are held down together for more than 1 second, the direction through the menu structure is reversed. Now when the SELECT button is pressed the direction is from right to left, bottom to top. In this mode, the LED on the Calibrator will flash. If the '+' and '-' buttons are held down together for more than 1 second again, the direction reverts back to the first direction and the Calibrator LED stops flashing.

The SELECT button is used to navigate through most of the menu structure, however, the Test menu (menu 19) is slightly different. Pressing the SELECT button will take you to the first item in the Test menu, (item 19.01 - Accelerator Demand). To navigate the Test menu, you need to use the '+' and '-' buttons. The '+' button moves up the Test menu and the '-' button moves back down. Pressing the SELECT button at any time exits the Test menu and moves to the first item in the menu structure (menu item 0.01 - Armature Current Limit).

The items which are displayed depends on the current system configuration and the Security Level.

Adjustments

Menus 0 to 12 are primarily used for configuring the system. All the personalities that the system uses to configure each function are in one of these menus. A brief description of the purpose of each menu is listed below. For more complete descriptions of each personality refer to the appropriate section in this manual.

Menu	Name	Purpose
0	Current Limits	Used to setup maximum currents for motor.
1	Braking Levels	Not Used
2	Accelerator	Used to setup acceleration and deceleration performance and to configure the accelerator input voltage range.
3	Creep Speed	Not Used
4	Bypass	Not Used
5	Maximum Speed	Used to setup maximum speeds.
6	Cutback 1 Speed	Not Used
7	Cutback 2 Speed	Not Used
8	Motor Setup	Used to setup motor control parameters.
9	Power Steer Timer	Not Used
10	Seat Delay	Not Used
11	Additional Personalities	Used to setup additional personalities. These are personalities which do not belong in any of the menus shown above, or they are deemed to be unsuitable for modification by service engineers or end users.
12	System Setup	Used to configure the system at a high level. Items to configure the system I/O and performance are located in here. It is recommended that items in this menu are configured first before any of the other personalities. Unlike the personalities in the other menus, changes to items in this menu do not take affect until the Keyswitch is recycled.

Table 2: Adjustment Menus

Status and Test Information

Menus 13 to 19 are primarily used for providing information about the system. Every parameter which the system measures is located in one of these menus. A brief description of the purpose of each menu is listed below.

Menu	Name	Purpose
13	System Status	If there is a fault active in the system, this menu provides information about what the fault is. Refer to the Diagnostics section for more information.
14	Motor Speed	Motor Speed as a percentage of the maximum RPM specified.
15	System Voltages	Used to display Battery and Capacitor Voltage measurements. The Battery Voltage measurement shows the voltage measured at the Keyswitch pin (pin 1 on connector B). The Capacitor Voltage measurement shows the voltage measured at the B+ terminal.
16	Motor Voltages	Used to show the voltage measured at the Point A terminals.
17	Motor Currents	Used to show the Battery Current Measurement.
18	Heatsink Temperature	Used to access the Heatsink Temperature measurement. Refer to the Temperature Monitoring section.
19	Test Menu	Used to access items which allow for testing of all the Analogue and Digital inputs available on connector B. Also displays unit information such as the Software Version, Controller Serial Number and the Personality Checksum. Refer to the appropriate sections for more information on each of these items.

Table 3: Status and Test Information Menus

Configuration

Configuration of the MillipaK controller is split into two categories – system and performance, which will be discussed in turn.

System Configuration

The MillipaK system configuration items relate to how the MillipaK will interface with connected hardware such as the system battery, vehicle control switches, accelerator and the traction motor.

System Voltage

The system voltage usually refers to the main system supply battery voltage. The controller uses this information to ensure low and high voltage settings are within an appropriate range.

System Voltage			Power Up
Calibrator Menu Reference:			12.07
Minimum	Maximum	Step Size	Default
24v	48v	2v	24v

System I/O Configuration

The digital inputs, analogue inputs and contactor drive outputs available on socket B can be configured in a number of ways to suit various applications. Table 4 shows a range of pre-determined settings which are available to the user and should cover the majority of applications, see below:

I/O Value	Description
1	Forward and Reverse switches.
2	Forward and Reverse switches with accelerator.
3	Forward and Reverse switches with accelerator and electric outboard reverse solenoid drive.

Table 4: Description of each I/O configuration.

If your application doesn't fit any of the above, please contact Sevcon with details of your requirements.

Each of the above configurations allocates the controller i/o as shown below:

Function	Value of I/O Configuration Item		
	1	2	3
Forward	B2	B2	B2
Reverse	B3	B3	B3
Accelerator		B10	B10
Line Contactor	B8	B8	B8
Reverse Solenoid Drive			B9

Table 5: I/O Functions

Notes:

1. Bx refers to Socket B pin numbers.
2. All setups have Forward and Reverse Switches and a Line Contactor.

I/O Configuration			Power Up
Calibrator Menu Reference:			12.06
Minimum	Maximum	Step Size	Default
1	3	1	As Required

Armature Current Limit

The armature current limit personality is provided to allow the user to limit the maximum current supplied to the motor to a value lower than the peak rating of the controller.

Armature Current Limit			Immediate
Calibrator Menu Reference:			0.01
Minimum	Maximum	Step Size	Typical Value
50A	ABR	10A	ABR

ABR – Armature **B**lock **R**ating refers to the controller maximum peak current.

The above personality allows the armature current limit to be set. The actual armature current limit control is performed using a control loop. The following two personalities can be used to setup this control loop.

Current Limit Prop Gain			Immediate
Calibrator Menu Reference:			0.02
Minimum	Maximum	Step Size	Typical Value
0	255	1	As set

Current Limit Int Gain			Immediate
Calibrator Menu Reference:			0.03
Minimum	Maximum	Step Size	Typical Value
0	255	1	As set

WARNING: Seek advice from SEVCON before changing these two personality values. Changing these can affect the capability of the current limit function which could damage the unit due to over-current. The factory set values should be suitable for most applications

Contactor chopping

This feature allows 24 V contactors to be used at all battery voltages 24V – 36V, by continuously monitoring the battery voltage and chopping the contactor output pins accordingly, to present an average voltage suitable for 24V coils. Chopping is selectable by the calibrator. Care must be taken to ensure that chopping is always selected if 24V contactors are being used on battery voltages higher than 24V. In applications > 24 volts contactors must be fitted with blow out magnets. Chopping can reduce the overall dissipation in the coils and allows only one set of contactors to be stocked for all battery voltages.

Chopping Frequency approx. = 800Hz (Slightly audible).

Typical contactor coil voltage during chopping = 16 volts.

Typical contactor coil voltage during energisation = 24 volts for 1 second.

There are 3 contactor chopping options available via the setup menu: Off, On and 24V. The off setting is used for nominal battery voltage coils, and the On setting is for 24V coils on higher voltage vehicles. Setting to 24V provides chopping for 24V coils and lamps without the drop to 16V after 1s.

When the electric outboard solenoid is configured, both the line contactor and electric outboard solenoid coil voltage will be battery voltage for 100ms during energisation and then reduced to 16 volts.

Chop Select			Power Up
Calibrator Menu Reference:			12.01
Options			Default
OFF	ON	24V	OFF

Accelerator Full /Zero Setting

The accelerator/analogue inputs are flexible in the range of signal sources they can accommodate and can be adjusted to minimise dead-bands and mechanical tolerances. Each analogue input has 2 adjustments associated with it to allow the input voltage range to be determined.

For the Traction Accelerator, for example, the 2 adjustments are called the “Accelerator Zero Level” and the “Accelerator Full Level”. If these were set to 0.20V and 4.80V then 0% pulsing would start at 0.20V at the input, increasing to 100% pulsing at 4.80V. For accelerators with decreasing voltage outputs, the Zero adjustment might be set to 3.5V and the Full adjustment to 0.0V. The Calibrator test menu shows the instantaneous voltage reading, and the equivalent % “push” for each input.

Accelerator Zero Volts			Immediate
Calibrator Menu Reference:			2.03
Minimum	Maximum	Step Size	Typical Value
0.00V	4.50V	0.02V	0.10V

Accelerator Full Volts			Immediate
Calibrator Menu Reference:			2.04
Minimum	Maximum	Step Size	Typical Value
0.00V	4.50V	0.02V	3.50V

Note that a 6 flash fault will occur if the full and zero levels are set within 0.50V of each other.

The PWM demand will vary between the Creep level and Maximum Speed level as the accelerator voltage varies between “Accelerator Zero” and “Accelerator Full”.

Motor Poles

The motor poles refer to the number of poles in the motor. The motor poles are used to calculate the mechanical speed of the motor.

Motor Poles			Power Up
Calibrator Menu Reference:			8.01
Minimum	Maximum	Step Size	Typical Value
2	20	2	8

Maximum Motor RPM

The maximum motor RPM is the maximum RPM when the motor is unloaded and maximum voltage is applied to the motor. The value is in 100rpm per step size.

Maximum Motor RPM			Power Up
Calibrator Menu Reference:			8.02
Minimum	Maximum	Step Size	Typical Value
10	40	1	20

Phase Adjustment

The phase offset personalities can be adjusted if the sensors are not aligned perfectly in the motor. A value of 128 represents a perfectly aligned motor.

Phase Offset - Forward			Immediate
Calibrator Menu Reference:			8.03
Minimum	Maximum	Step Size	Typical Value
1	255	1	128

Phase Offset - Reverse			Immediate
Calibrator Menu Reference:			8.04
Minimum	Maximum	Step Size	Typical Value
1	255	1	128

The system corrects the phase angle of the applied voltage to achieve a unity power factor. The feature can disabled if required.

NOTE: If this feature is disabled, the phase current could be higher than that measured by the system. Only disable this feature if it is known high phase currents can not occur.

Power Factor Phase Correction		Power Up
Calibrator Menu Reference:		12.05
Options		Default
OFF	ON	ON

Performance

Various parameters may be adjusted to tailor the performance of the vehicle to customer requirements.

Control Mode

The method of motor control may be switched between Torque and Speed control.

Control Mode	Power Up
Calibrator Menu Reference:	12.03
Options	Default
Torque	Speed
Speed	Torque

Speed Control PI Gains

The system uses a PI algorithm for Speed Control. As with all PI algorithms, there are proportional and integral gains which need to be setup correctly. The following diagram illustrates the affect of proportional and integral gains on a standard PI control loop.

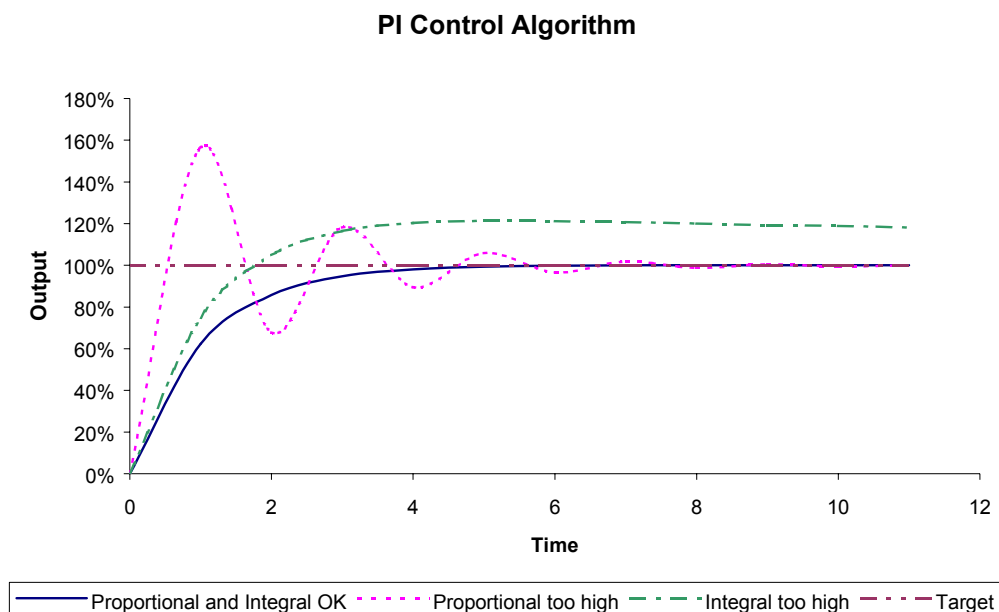

As can be seen, too much proportional gain can cause large over-shoot and poor control to occur from the PI Control Loop and too much integral gain can cause the speed to over-shoot and take a long time to get back to the required output.

To set up the speed control proportional and integral gains use the following guidelines.

1. Set the speed target to approximately 50%.
2. Set the speed control proportional and integral terms to 0. Increase the proportional term slightly. The motor will drive very slowly but the control will be smooth. Increase the speed control proportional until the motor control is no longer smooth. Once this happens reduce the speed control proportional value to the point at which the control became unstable. Set the speed control proportional to half this value. The motor control will now be smooth, but it will not reach the required speed. This is where the speed control integral gain comes into use.
3. Increase the speed control integral gain to a point where the motor can easily reach the required speed in a time equal to the Acceleration Delay. Ensure that the integral term is not set too high, otherwise the motor speed will over-shoot.
4. Reduce the speed target to approximately 5%.
5. Check that the motor control is still smooth. If the control is unstable, decrease the proportional gain until the control is stable.

The following two personalities can be used to setup the control loop.

Speed Proportional Gain			Immediate
Calibrator Menu Reference:			2.05
Minimum	Maximum	Step Size	Typical Value
0	255	1	48

Speed Integral Gain			Immediate
Calibrator Menu Reference:			2.06
Minimum	Maximum	Step Size	Typical Value
0	255	1	24

Acceleration Delay

This is an adjustable delay to ramp up the armature voltage from 0% on to 100% in Torque mode or to ramp up the speed demand from 0% to 100% in Speed mode, and can be used to ensure smooth acceleration.

Acceleration Delay			Immediate
Calibrator Menu Reference:			2.01
Minimum	Maximum	Step Size	Typical Value
0.1S	5.0S	0.1S	2.0S

Deceleration Delay

This is an adjustable delay to ramp down the armature voltage from 100% on to 0% in Torque mode or to ramp down the speed demand from 100% to 0% in Speed mode, and can be used to provide a smooth reduction of power to the motor.

Deceleration Delay			Immediate
Calibrator Menu Reference:			2.02
Minimum	Maximum	Step Size	Typical Value
0.1S	5.0S	0.1S	2.0S

Maximum Speed

Adjustment limits the maximum applied voltage to the armature in Torque mode or the maximum speed as a percentage of the maximum speed (rpm) in Speed mode.

Maximum Speed			Immediate
Calibrator Menu Reference:			5.01
Minimum	Maximum	Step Size	Typical Value
0%	100%	1%	100%

Features

The MillipaK controller has several features designed to offer the user maximum flexibility, safety and performance whilst ensuring the controller is protected against adverse or harsh driving conditions. These features can be split into three categories – standard controller features, safety features and controller protection features.

Standard Controller Features

The following section details the standard features found on a MillipaK controller.

Drive Hours Meter

The MillipaK maintains a log of the number of hours during which the controller is providing Drive functionality. The Drive Hours Meter runs whenever the vehicle is driving or braking. The current number of logged Drive hours can be viewed using the Calibrator. Refer to the Calibrator section for more information.

Line Contactor Drop out

The controller will close the line contactor once a successful power up sequence has been carried out, after which drive operation can be achieved. The line contactor will remain closed unless it is opened following a serious fault or power being disconnected.

A further configurable option is available where the line contactor is opened (dropped out) if no drive activity has occurred for a period exceeding the line contactor dropout delay personality. If drive operation is selected once the line has been opened then it will be closed again so that drive operation can occur. Line contactor dropout operation can be selected in the PERS set up:

Line Contactor Drop out		Power Up
Calibrator Menu Reference:		12.04
Options		Default
OFF	ON	OFF

Line Contactor Drop out Delay			Immediate
Calibrator Menu Reference:			11.01
Minimum	Maximum	Step Size	Typical Value
1s	60s	1s	5s

Electric Outboard Drive and Low Battery Warning

The Electric Outboard Drive is used to drive a solenoid, which, in turn, activates a hook that holds the propeller in place when the REVERSE direction is selected. It is also used to drive an alarm buzzer when the FORWARD direction is selected in conjunction with the Low Battery Warning feature.

When the REVERSE direction is selected the solenoid engages the hook which holds the propeller in place by outputting battery voltage for 100ms, after which the output is chopped at 16V.

When the FORWARD direction is selected, the buzzer alarm will sound if the following is true:

- The average battery voltage drops below the Battery Warning Level personality setting continuously for a period of time longer than that specified by the Battery Warning Timer personality setting.

If the above is true, the buzzer will sound intermittently, and will be ON for 5s and OFF for 20s.

In order for the Electric Outboard Drive to become available, I/O configuration 3 must be selected.

Low Battery Warning Level			Immediate
Calibrator Menu Reference:			11.07
Minimum	Maximum	Step Size	Typical Value
0.0V	48.0V	0.5V	16.0V

Low Battery Warning Timer			Immediate
Calibrator Menu Reference:			11.08
Minimum	Maximum	Step Size	Typical Value
0.0s	20.0s	0.1s	0.0s

Temporary Current Boost

This is a feature intended to allow the user to temporarily boost the armature current limit in an attempt to improve acceleration.

Immediately after drive demand is requested, the system will set the armature current limit to the Temporary Armature Current Limit personality (not to exceed the controller's block rating) for the time period specified by the Temporary Armature Current Limit personality setting. After the expiration of the Temporary Armature Current Limit Timer, the system will reset the armature current limit according to the Armature Current Limit personality.

Temporary Armature I Limit			Immediate
Calibrator Menu Reference:			0.04
Minimum	Maximum	Step Size	Typical Value
5A	330A	10A	100A

Temporary Armature I Limit Timer			Immediate
Calibrator Menu Reference:			0.05
Minimum	Maximum	Step Size	Typical Value
0S	10S	1S	4S

Safety Features

The features listed in this section are designed with the safety of the operator in mind.

Start Up Sequence

At keyswitch on, the Direction switches must be in the neutral condition simultaneously at least once before drive can be selected. This is a safety feature to help prevent unexpected movement immediately after power up.

Alternatively, the system may be programmed not to check the Direction switches at power on. This option is programmable:

Direction Switch Checking		Power Up
Calibrator Menu Reference:		12.02
Options		Default
OFF	ON	OFF

Idle Fault

This feature is intended to prevent accidents caused by unintentional movement.

The system will exhibit a severe fault (cannot be cleared without a key recycle) and a 2 flash fault will be displayed by the Diagnostic LED mounted on the controller, if the following is true:

- system is powered up
- forward or reverse is closed
- accelerator push is zero
- The above conditions are both true continuously for the time specified by the Idle Timer personality.

Setting the Idle Timer personality at zero disables the feature.

Idle Timer			Immediate
Calibrator Menu Reference:			11.02
Minimum	Maximum	Step Size	Typical Value
0s	255s	1s	240s

Motor Stall Protection

By monitoring the motor current and voltage over a period of time, the controller is able to detect if a motor stall condition has occurred.

If the armature current rises above the level specified by the Stall Motor Current personality, while the motor voltage drops below the level specified by the Stall Motor Voltage personality, for a continuous period of time longer than that specified by the Stall Timer personality setting, then a motor stall condition will be identified. As a result, the controller will exhibit a severe fault (cannot be cleared without a key recycle), accompanied by a 9 flash fault being displayed by the Diagnostic LED mounted on it.

Setting the Stall Timer personality to zero disables the feature.

Stall Timer			Immediate
Calibrator Menu Reference:			8.05
Minimum	Maximum	Step Size	Typical Value
0s	60s	1s	2s

Stall Motor Voltage			Immediate
Calibrator Menu Reference:			8.06
Minimum	Maximum	Step Size	Typical Value
1V	24V	1V	8V

Stall Motor Current			Immediate
Calibrator Menu Reference:			8.07
Minimum	Maximum	Step Size	Typical Value
10A	330A	10A	50A

Fail-safe

The controller's safety system includes a microprocessor watchdog which can detect software failure, and a hardware fail-safe system which can prevent dangerous runaway conditions in the event of certain hardware failures.

Every time the controller is powered-up, the software checks that the fail-safe circuit is able to switch off the MOSFETs and open the contactors.

Controller Protection Features

There are several in built features which are designed to protect the MillipaK controller from damage due to excessive load currents, voltages and prolonged periods of high demand.

Temperature Monitoring

If the temperature of the power frame exceeds 75°C its maximum available current will be reduced. Note, however, that if the set current limit is less than the maximum available current limit actual cutback will occur at progressively higher temperatures than 75°C. The thermal cutback ensures that the maximum heatsink temperature is limited to 90°C (See Figure 5). When actual cutback occurs the diagnostic LED will flash 8 times. Inspection of the calibrator fault messages will indicate which unit is in thermal cutback.

Thermal Cutback Characteristic

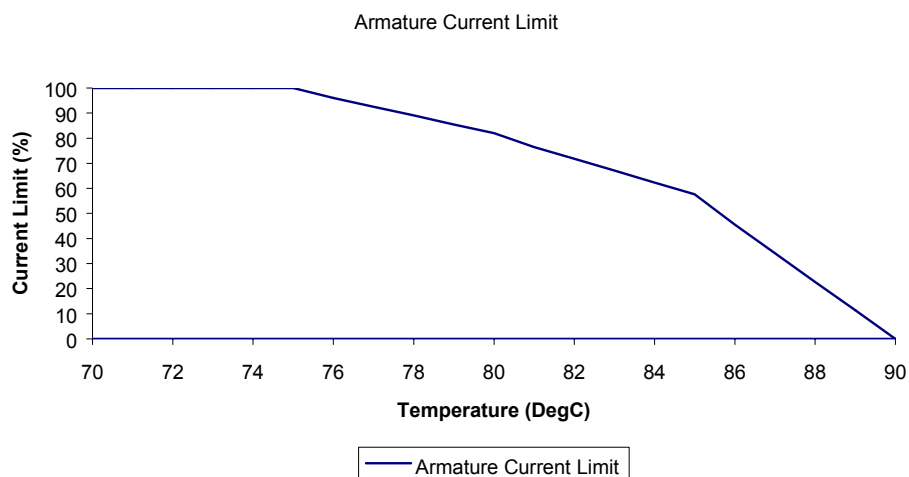

Figure 5: Armature Thermal Cutback Characteristic

Timed Current Cutback

During periods of high current usage the power components of the controller produce considerable heat. Under normal circumstances the controller will cutback the maximum current supplied to the load when the heatsink temperature rises above a safe level for the controller components. However, when the current supplied is close to the maximum rating of the controller the temperature rise of the components leads the heatsink temperature by up to 40°C. If this situation was allowed to arise damage may result in the controller. In order to prevent this situation a timed current cutback feature is incorporated in the MillipaK controller, which works as described below:

The controller monitors the load current during a 30 second period and categorises the value into low, medium, high or high & hot. The new current limit is then calculated as shown in Table 6.

Old Current Limit (% of ABR)	New Current Limit (% of ABR)			
	Low	Medium	High	High & Hot
100%	100%	90%	90%	60%
90%	100%	90%	80%	60%
80%	90%	80%	70%	60%
70%	80%	80%	60%	60%
60%	70%	70%	60%	60%

Table 6: Timed Current Limit Cutback Levels

ABR - Is the Armature Block Rating. The controller is deemed to be ‘Hot’ if the measured heatsink temperature is above 50°C.

The system will limit the current through the armature to the calculated limit during drive. The system will not apply any Timed Current Limit cutback during braking.

Under-voltage and over-voltage protection

In order to prevent a sudden loss in power, the controller will begin to linearly ramp down the current limit, once the average battery voltage falls below a pre-set under-voltage start level. The current will be ramped down to a minimum of 20A and a 7 flash fault indicated if the averaged battery voltage falls below the under-voltage cut-out level.

To protect the controller from over-voltage caused by prolonged regen when ramping down to zero speed, the regen current limit will be reduced when the average battery voltage reaches the over-voltage start level. The current will be ramped down to a minimum of 20A and a 7 flash fault indicated if the averaged battery voltage exceeds the over-voltage cut-out level.

Nominal Battery Voltage	Under-voltage Cutout	Under-Voltage Start (adjustable)	Over-voltage Start (adjustable)	Over-voltage Cut-out
24 V	14.5V	Under Voltage Cut-out up to System V	System V up to Over Voltage Cut-out	30.0V
36 V	14.5V			45.0V
48 V	14.5V			57.0 V

Table 7: Under and Over-Voltage Cutback Levels

The following calibrator menu items are used to set these values.

Low Voltage Start			Immediate
Calibrator Menu Reference:			11.03
Minimum	Maximum	Step Size	Typical Value
Low V Cutout	System Voltage	0.5V	18.0V

Low Voltage Cutout			Immediate
Calibrator Menu Reference:			11.04
Minimum	Maximum	Step Size	Typical Value
14.5V	Low V Start	0.5V	16.0V

High Voltage Start			Immediate
Calibrator Menu Reference:			11.05
Minimum	Maximum	Step Size	Typical Value
System Voltage	High V Cutout	0.5V	High V Cutout

High Voltage Cutout			Immediate
Calibrator Menu Reference:			11.06
Minimum	Maximum	Step Size	Typical Value
High V Start	50.0V or 58.0V	0.5V	50.0V or 58.0V

The maximum High Voltage Cutout depends on the level of the System Voltage item. If the System Voltage is set to 36V or lower, then the maximum is 50.0V. If the System Voltage is set greater than 36V, then the maximum is 58.0V.

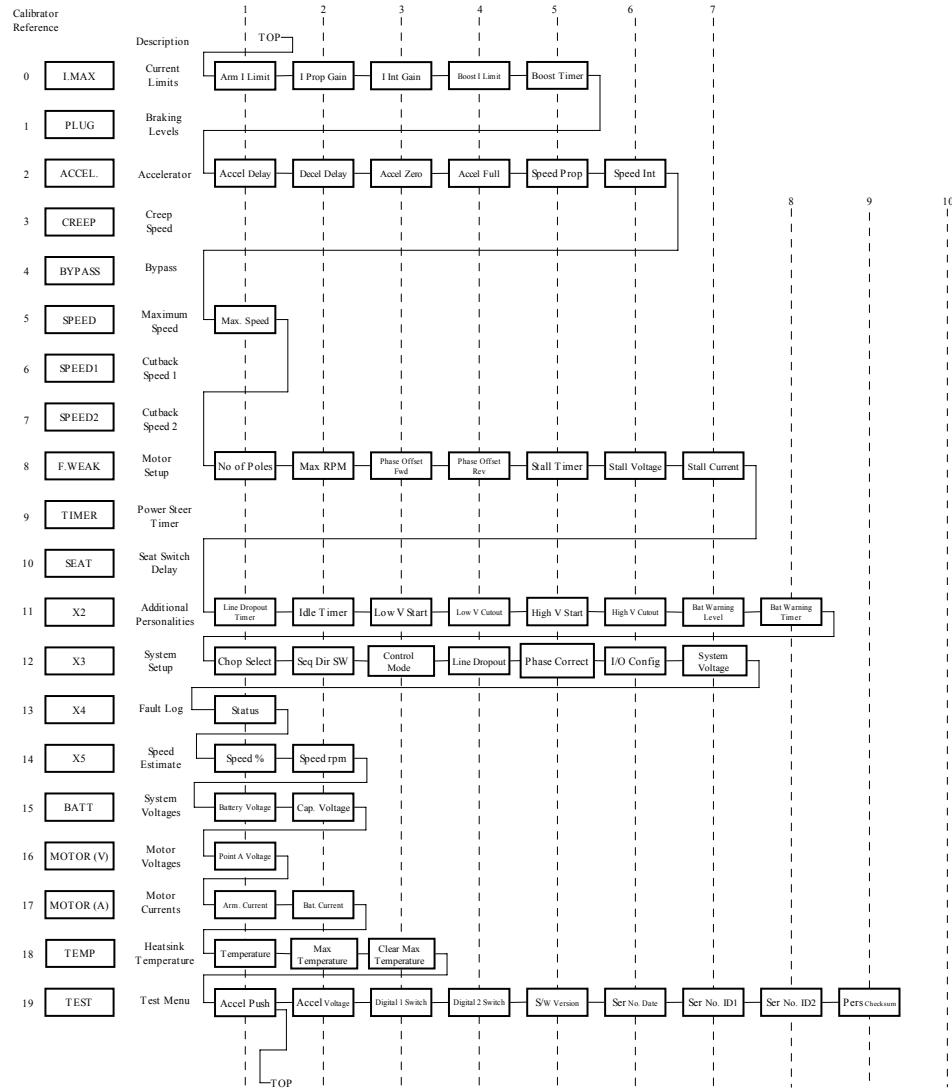

Map for BPM Controller System Version UK0123 - 11th February 2004

Navigation

The operator moves through the Calibrator Map by pressing the SELECT key. The solid line shows the path through the menu structure when the SELECT key is pressed.

In Service Mode (no Password entered) only the items shown with a thick solid border are displayed. When the next item is hidden (Engineering or All adjust access only), the calibrator moves on the next displayable item. Items which are not configured will also be hidden, ie the bypass items will not be displayed if the bypass contactor is not configured.

In Engineering Mode (Password entered) the items shown with a solid border are displayed. When the next item is hidden (All adjust access only), the calibrator moves on the next displayable item. Items which are not configured will also be hidden.

In All Adjust Mode (Password entered) all the items (solid and dashed borders) are displayed.

Direction

By default, the Calibrator moves from left to right through the menu structure. If the operator presses and holds the '←' and '→' keys for more than 1 second the navigation direction changes and the Calibrator will move from right to left through the menu structure. The direction can be restored by holding the '←' and '→' keys for 1 second again.

The direction is indicated by the LED on the Bar Graph. If the LED is lit steadily, the direction is from left to right, else if the LED is flashing the direction is from right to left.

Information Items

The Test menu only shows information items that cannot be modified. The operator can move up and down the menu using the '↑' and '↓' keys. As before, items with a dashed border are only displayed in All Adjust Mode. If the Operator presses the SELECT key the Calibrator moves to the next menu.

Item Identification

The operator can identify the current item by holding down the '←' and '→' keys. For example, holding down the '←' and '→' keys on the High V Cutout personality will display 11.09 (Menu 11 (IMAX is menu 0), Item 9). The operator will use the User Manual to identify the personality from the ID.

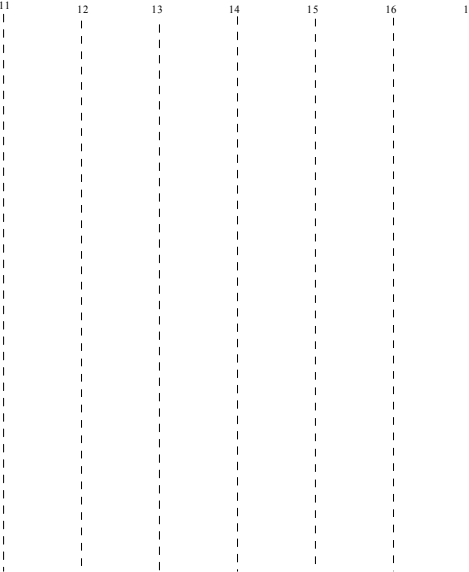

Commissioning Checklist

- Controller Mounted on suitable flat heatsink with appropriate heatsink compound ?
- Power wiring checked, shortest routes taken where possible ?
- Light wiring checked, use calibrator to verify controller correct switch operation.
- Accelerator set-up and checked 0 – 100% ?
- Personalities all set, checked and record filled out ?

Personality Record

Personality		New Setting	Range	
			Minimum	Maximum
0.01	Armature Current Limit		50A	ABR ³
0.02	Imax Proportional Gain		0	255
0.03	Imax Integral Gain		0	255
0.04	Boost Current Limit		50A	ABR
0.05	Boost Timer		0s	10s
2.01	Acceleration Delay		0.1s	5.0s
2.02	Deceleration Delay		0.1s	5.0s
2.03	Accelerator Zero V ⁸		0.00V	4.50V
2.04	Accelerator Full V ^{8,9}		0.00V	4.50V
5.01	Maximum Speed		0%	100%
8.01	Number of Poles		2	20
8.02	Maximum Motor RPM/100		10	80
8.03	Phase Offset – Forward		1	255
8.04	Phase Offset – Reverse		1	255
8.05	Stall Timer		0s	60s
8.06	Stall Voltage		1V	48V
8.07	Stall Current		10A	ABR
11.01	Line Contac. Dropout Delay		1s	60s
11.02	Low Voltage Start		Low V Cutout	System Voltage
11.03	Low Voltage Cutout		14.5V	Low V Start
11.04	High Voltage Start		System Voltage	High V Cutout
11.05	High Voltage Cutout		High V Start	50.0V or 58.0V ⁷
11.06	Low Battery Warning Level		14.5V	58.0V
11.07	Low Battery Warning Timer		0.0s	20.0s
12.01	Chop Select		OFF/ON/24V	
12.02	Drive Switch Check		OFF/ON	
12.03	Control Mode		TORQUE/SPEED	
12.04	Line Cont Drop out		OFF/ON	
12.05	Power Factor Correction		OFF/ON	
12.06	I/O Configuration		1	3
12.07	System Voltage		24V	48V

Table 8: Personality Record

Fault Finding

The MillipaK controller includes a number of features designed to help the user track down operational faults, wiring faults or internal controller faults.

The **Diagnostic LED** mounted next to the calibrator connectors on the front of the controller serves as a simple diagnostic tool as explained below:

ON	No fault, normal condition
OFF	Internal controller fault
1 flash	Personality out of range
2 flashes	Illegal start condition
3 flashes	MOSFET Short Circuit
4 flashes	Contactor fault
5 flashes	Not used
6 flashes	Accelerator wire off fault
7 flashes	Low or High battery voltage
8 flashes	Over temperature or timed cutback
9 flashes	Rotor Position Sensor Fault

Table 9: Flash Fault Descriptions

In addition to the LED indication a more detailed description of any faults detected may be found by using the calibrator. Menu item number 13.01 gives a code which corresponds to the following detected faults:

ID	Fault	Description	Flash Fault
0	System OK		On
1	Thermal Cutback	Maximum power available to the motor has been reduced due to excessive Heatsink temperature.	8
2	Timed Current Limit Cutback	Maximum power available to the motor has been reduced by the Timed Current Limit Cutback function.	8
3	Accelerator Wire Off	Input wire from accelerator has been disconnected.	6
4	Accelerator Power Up Fault	Accelerator push > 5% at power up	6
5	Two Direction Fault	Two directions selected together.	2
6	Sequence Fault	Direction or FS1 switch closed at power up.	2
7	System Idle Fault	System Idle timer expired	2
8	System Stall Fault	System stall condition occurred	9
9	Low Battery Fault	Battery voltage is too low.	7
10	High Battery Fault	Battery voltage is too high.	7
11	High Battery Fault with Line Contactor Open	Battery voltage is too high before the line contactor is closed	7

12	Configuration Range Fault	A personality is out of range.	1
13	Configuration CRC Fault	The personality CRC is incorrect	1
14	Line Contactor did not Close Fault	Line contactor is open circuit.	4
15	Line Contactor Welded Fault	Line contactor is welded.	4
16	RPS Fault	Rotor position sensor is in an invalid state	9
17	MOSFETs Short Circuit	The armature MOSFETs have been detected as being short circuit.	3
18	MOSFET Off	MOSFETs did not pulse during power on failsafe checks (failsafe circuit enabled).	0
19	MOSFET On	MOSFETs pulsed during power on failsafe checks (failsafe circuit disabled).	0
20	Power Up MOSFET Short Circuit	The armature MOSFETs have been detected as being short circuit at system power up.	3
21	Drive 2 Off	Contactors 2 did not pulse during power on failsafe checks (failsafe circuit enabled).	0
22	Drive 2 On	Contactors 2 pulsed during power on failsafe checks (failsafe circuit disabled).	0
23	Drive 1 Off	Contactors 1 did not pulse during power on failsafe checks (failsafe circuit enabled).	0
24	Drive 1 On	Contactors 1 pulsed during power on failsafe checks (failsafe circuit disabled).	0

Table 10: Fault Numbers and Descriptions

Fault Clearance

Any fault indication will be cleared by re-initiating the start sequence after the cause of the fault has been removed.

Fault Reporting Form

Sevcon is committed to improving the quality of all of its products. Please help us by using this form to report faults to Sevcon. Please give as much detail as possible. Use extra sheets if required. Fax this form to +44 191 482 4223.

Your Name		Telephone Number	
Your Company		email address	
Vehicle Manufacturer		Vehicle Type	
Controller Type		Part number	
Serial Number		Software Version	
Date / Time that fault first occurred.			
Exact Fault Message (calibrator or display)			
When did the fault message appear?	during drive / when the vehicle stopped / in neutral / after a keyswitch off-on (delete as applicable)		
How did the fault occur? Please describe: The vehicle speed. The approximate gradient (up or down hill) Pedal and switch changes by the driver What happened to the vehicle when the fault occurred			
What is the status of the vehicle now? Is there a fault message at key-switch on? Can it be driven?			

Table 11: Fault Reporting Form

Software Version and Serial Number indication

For identification purposes and to assist in queries, the Software version, and the controller serial number are indicated in the calibrator Test Menu.

The Software version is shown in the Test menu. When giving the Software Version, the entire number should be quoted (i.e. MM.mm.nn).

The Serial Number is shown across three items in the Test menu. The first item is the date code and the next two are the identifier. All these items need to be used to get the complete serial number. The format is:

Test Item:	Ser No. Date	Ser No. ID1	Ser No. ID2
Serial Number:	MMYY	AA	BB

Table 12: Serial Number Format

MMYY gives the month and year when the controller was manufactured. (e.g. 0701 indicates July, 2001). AABB are combined to give a 4 digit identifier which is simply a number from 0001 to 9999. When giving the Serial Number, the entire number should be quoted (i.e. MMYYAABB).

The MillipaK range of controllers use the latest FLASH technology to allow In System Reprogramming. This is achieved without having to remove the controller from its installation – all that is needed is connection to the 6-way calibrator socket.

Specifications

The following specifications apply to all MillipaK controllers.

Power Configurations

At present the MillipaK SBPM controller is available in the following power configurations:

Housing	Armature
HP Large	250A

Table 13: Power Configurations

The MillipaK SBPM range of controllers operate from 24-36v batteries.

EMC standards

All MillipaK variants are tested to and conform to EN12895.

Socket B protection

All user connections on socket B are protected against indefinite short circuit to battery minus and battery positive.

Contactors drive ratings

All contactor drives are rated at 3A peak (10s) and 1.5A continuous. All the drives have reverse battery connection protection, inbuilt freewheel diode and are internally protected against short circuit.

Analogue Input Impedance

The two analogue inputs are internally pulled up to +12v via a 12k resistor. This is primarily designed for use with 5k potentiometers, but may also be used with suitable voltage sources.

Digital Input Impedance

The digital inputs are internally pulled up and are active LOW. They therefore must be connected to battery minus to operate a function. Maximum resistance to battery minus to operate is 500ohms.

EMC Guidelines

The following guidelines are intended to help vehicle manufacturers to meet the requirements of the EC directive 89/336/EEC for Electromagnetic Compatibility.

Any high speed switch is capable of generating harmonics at frequencies that are many multiples of its basic operating frequency. It is the objective of a good installation to contain or absorb the resultant emissions.

All wiring is capable of acting as a receiving or transmitting antenna. Wiring should be arranged to take maximum advantage of the structural metal work inherent in most vehicles. Vehicle metalwork should be electrically linked with conductive braids.

Power Cables

All cables should be routed within the vehicle framework and kept as low in the structure as is practical - a cable run within a main chassis member is better screened from the environment than one routed through or adjacent to an overhead guard.

Power cables should be kept short to minimise emitting and receiving surfaces

Shielding by the structure may not always be sufficient - cables run through metal shrouds may be required to contain emissions.

Parallel runs of cables in common circuits can serve to cancel emissions - the battery positive and negative cables following similar paths is an example.

Tie all cables into a fixed layout and do not deviate from the approved layout in production vehicles. A re-routed battery cable could negate any approvals obtained.

Signal Cables

All wiring harnesses should be kept short.

Wiring should be routed close to vehicle metalwork.

All signal wires should be kept clear of power cables or made from screened cable

Control wiring should be kept clear of power cables when it carries analogue information - for example, accelerator wiring.

Tie all wiring securely and ensure wiring always follows the same layout.

Controller

Thermal and EMC (emissive) requirements tend to be in opposition.

Additional insulation between the controller assembly and the vehicle frame work reduce capacitive coupling and hence emissions but tend to reduce thermal ratings. A working balance needs to be established by experiment.

The complete installation should be documented, in detail, and faithfully reproduced on all production vehicles. When making changes, consider their effect on compliance ahead of any consideration of cost reduction or other "improvement".